

Vacuum sack lifter

Ex AVAILABLE CUSTOM MADE

Vacuum Sack Lifter

All types of sacks

OBJECTIVES

Effortless vacuum lifting of all types of sacks from 10 to 80 kg and increased productivity. A simple and reliable means for a single operator to handle sacks from 10 to 80 kg.

Advantages :

- Effortless lifting
- Increased performance and productivity
- Optimal working conditions
- Improvement in ergonomics
- Increased operator safety
- Very little maintenance required

EXAMPLES OF INSTALLATIONS

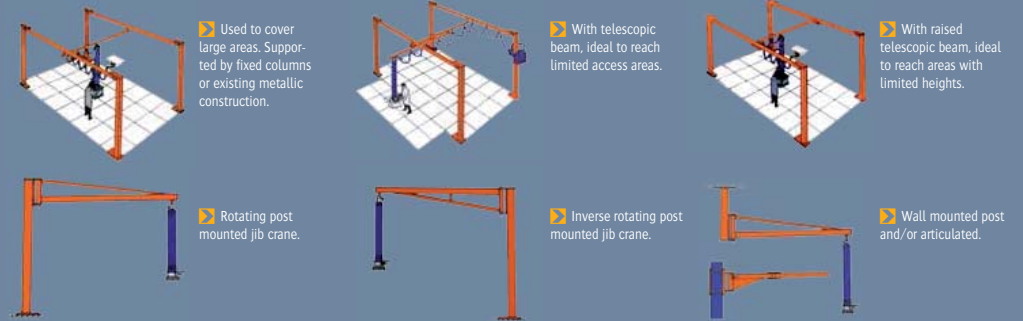

Triangular post mounted jib crane to provide a lifting stroke of 1,700 mm (overhead room 3m.)

Suction tube

Direct transmission vacuum pump which significantly reduces maintenance and noise (75 dB)

360° rotation lifting tube

Lifting head

Large suction foot

Sack dumping unit

Air filter for handling dusty bags

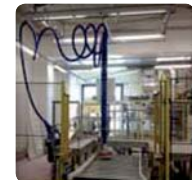

▶ **Roller conveyor:** possibility to install the manipulator near the roller conveyor to improve the ergonomics of the work station

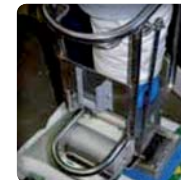

▶ **Vacuum sack lifter:** fitted with a control handle equipped with a stay-put Lever valve allowing a self-stabilization of the load at any height, without any adjustment. Ergonomic handle design, preventing wrist elongation



▶ **Rubber bale**

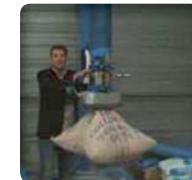

▶ **Hessian bags:** vacuum spike gripper to lift sacks of grains

Advantages

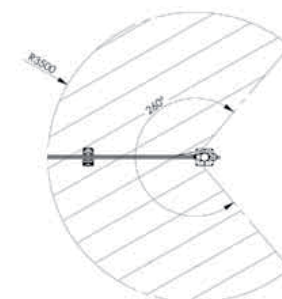
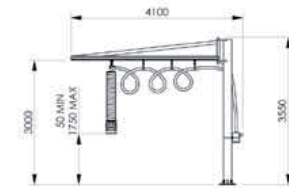
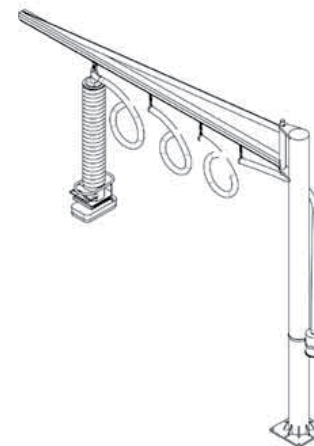

Options



Protection cover



Oversized filter for dusty bags

See all our options on pages 18-19